

ALL DIMENSIONS ARE CLEAR INSIDE TO FINISHED DRYWALL

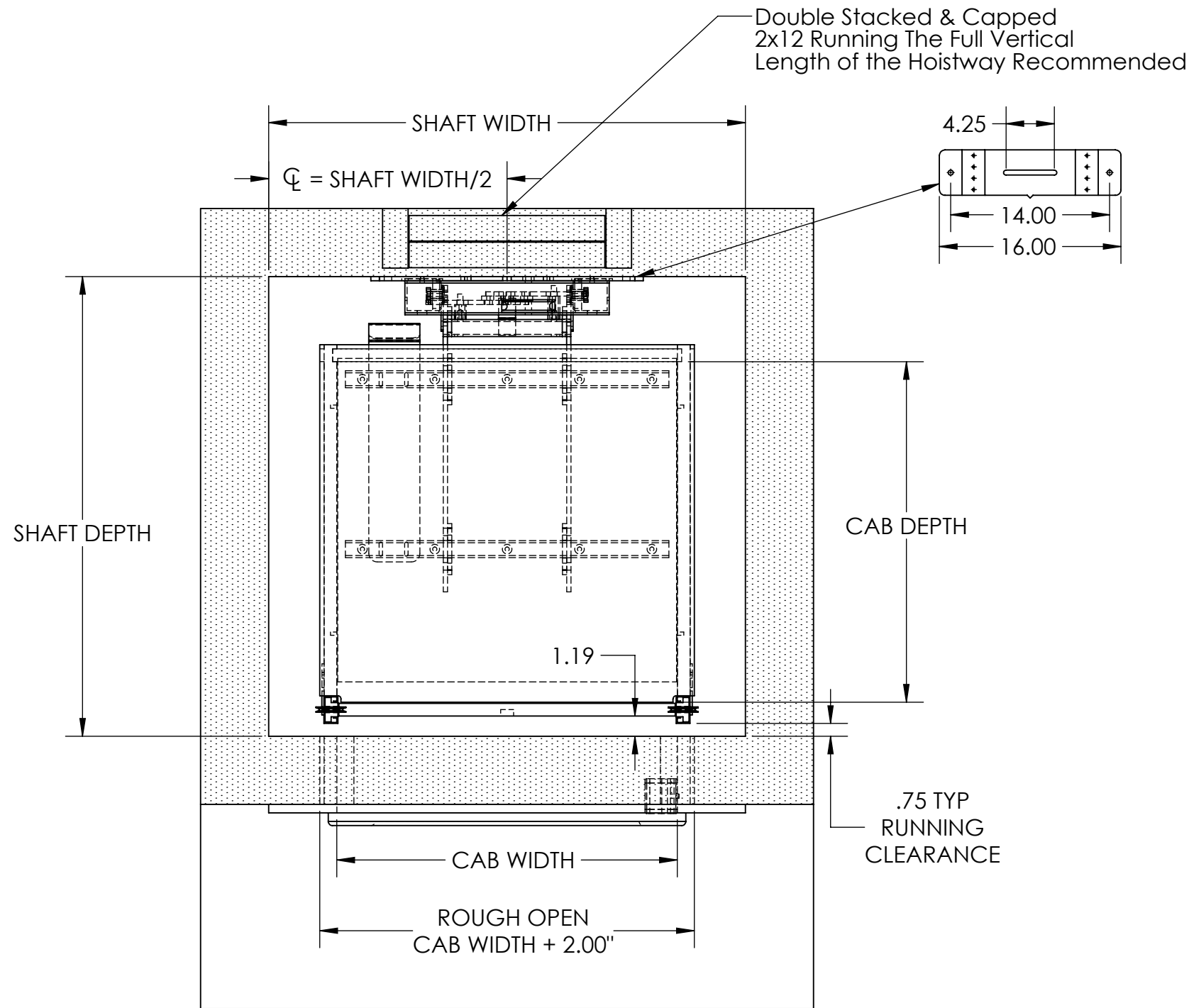

REAR RAIL CONFIGURATION CHART

CAB WIDTH	MIN SHAFT WIDTH	CAB DEPTH	CRITICAL SHAFT DEPTH
14"	24"	14"	21"-22"
15"	24"	15"	22"-23"
16"	24"	16"	23"-24"
17"	25"	17"	24"-25"
18"	26"	18"	25"-26"
19"	27"	19"	26"-27"
*20"	28"	*20"	27"-28"
21"	29"	21"	28"-29"
22"	30"	22"	29"-30"
23"	31"	23"	30"-31"
*24"	32"	*24"	31"-32"
SIZES OVER 24" REQUIRE 300LB OVERSIZED UPCHARGE			
25"	33"	25"	32"-33"
26"	34"	26"	33"-34"
27"	35"	27"	34"-35"
28"	36"	28"	35"-36"
29"	37"	29"	36"-37"
*30"	38"	*30"	37"-38"
CAB HEIGHTS AVAILABLE IN 30.00" & 36.00"			
*STANDARD SIZES			

**STRONGLY RECOMMEND LEAVING FRONT OF HOISTWAY OPEN AT BOTTOM FLOOR FOR INSTALLATION.
ACCESS HATCH RECOMMENDED AT MOTOR LOCATION / MOTOR LOCATION RECOMMENDED AT BOTTOM (TOP OPTIONAL).
SHAFT CONTRUCTION TO MEET ALL LOCAL JURISDICTION REQUIREMENTS.**



MODEL	QS-200 / QSC-300 DUMBWAITER
CAPACITY	200 LBS STANDARD / 300LBS OVERSIZE PACKAGE OPTIONAL
SPEED	32 FPM (Nominal)
DRIVE	CHAIN DRIVE GEAR MOTOR
OPERATION	AUTOMATIC OPERATION, MANUAL DOORS
ELECTRICAL REQUIREMENTS	REQUIRES A DEDICATED CIRCUIT, 120VAC, 15AMP OUTLET WITHIN SIGHT OF THE MOTOR.
CODE	AMSE 17.1.7

DO NOT SCALE DRAWING	NAME	DATE	PROJECT NAME
	KSB	2-11-19	
APPROVAL STATUS:	PROPRIETARY AND CONFIDENTIAL		PROJECT LOCATION
	APPROVED	THE INFORMATION CONTAINED IN THIS DRAWING IS THE SOLE PROPERTY OF AMERIGLIDE. ANY REPRODUCTION IN PART OR AS A WHOLE WITHOUT THE WRITTEN PERMISSION OF PLI IS PROHIBITED.	
APPROVED AS NOTED	COMMENTS:		Generic
REVISE AND RESUBMIT	SCALE	DWG. NO.	REV.
SIGNATURE	A		
	SCALE 1:16		SHEET 1 OF 4

ALL DIMENSIONS ARE CLEAR INSIDE TO FINISHED DRYWALL

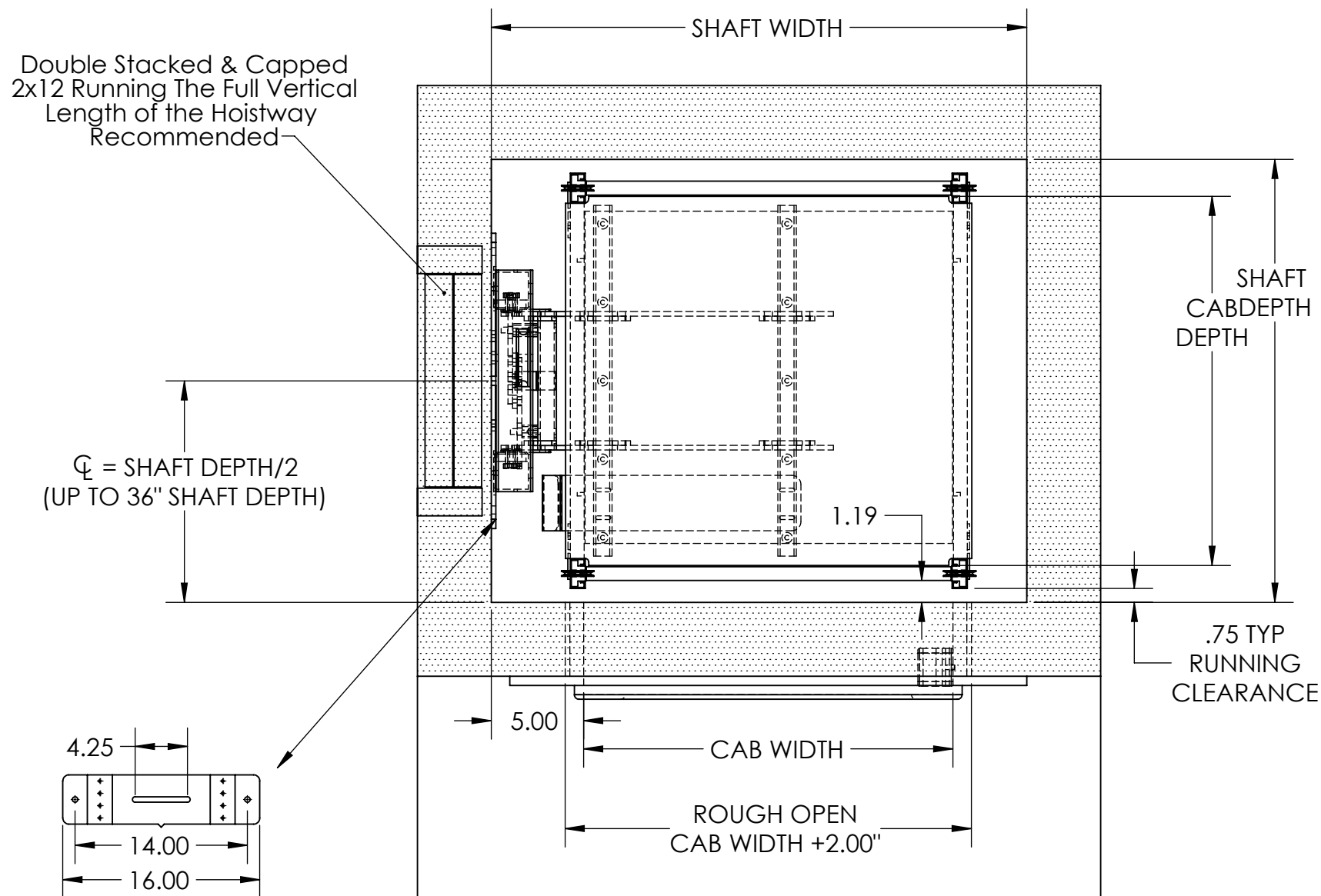

SIDE RAIL CONFIGURATION CHART					
CAB WIDTH	SHAFT WIDTH	CAB DEPTH	MINIMUM FRONT ONLY SHAFT DEPTH	CRITICAL PASS THRU SHAFT DEPTH	
14"	24"	-	-	-	
15"	24"	-	-	-	
16"	24"	-	-	-	
17"	25"	17"	22"	21"	
18"	26"	18"	23"	22"	
19"	27"	19"	24"	23"	
*20"	28"	*20"	25"	24"	
21"	29"	21"	26"	25"	
22"	30"	22"	27"	26"	
23"	31"	23"	28"	27"	
*24"	32"	*24"	29"	28"	
SIZES OVER 24" REQUIRE 300LB OVERSIZED UPCHARGE					
25"	33"	25"	30"	29"	
26"	34"	26"	31"	30"	
27"	35"	27"	32"	31"	
28"	36"	28"	33"	32"	
29"	37"	29"	34"	33"	
*30"	38"	*30"	35"	34"	
CAB HEIGHTS AVAILABLE IN 30.00" & 36.00"					
*STANDARD SIZES					

**STRONGLY RECOMMEND LEAVING FRONT OF HOISTWAY OPEN AT BOTTOM FLOOR FOR INSTALLATION.
ACCESS HATCH RECOMMENDED AT MOTOR LOCATION / MOTOR LOCATION RECOMMENDED AT BOTTOM (TOP OPTIONAL).
SHAFT CONTRUCTION TO MEET ALL LOCAL JURISDICTION REQUIREMENTS.**



MODEL	QS-200 / QSC-300 DUMBWAITER
CAPACITY	200 LBS STANDARD / 300LBS OVERSIZE PACKAGE OPTIONAL
SPEED	32 FPM (Nominal)
DRIVE	CHAIN DRIVE GEAR MOTOR
OPERATION	AUTOMATIC OPERATION, MANUAL DOORS
ELECTRICAL REQUIREMENTS	REQUIRES A DEDICATED CIRCUIT, 120VAC, 15AMP OUTLET WITHIN SIGHT OF THE MOTOR.
CODE	AMSE 17.1.7

DO NOT SCALE DRAWING	NAME	DATE	PROJECT NAME
	KSB	2-11-19	
APPROVAL STATUS:	PROPRIETARY AND CONFIDENTIAL		PROJECT LOCATION
	APPROVED	THE INFORMATION CONTAINED IN THIS DRAWING IS THE SOLE PROPERTY OF AMERIGLIDE. ANY REPRODUCTION IN PART OR AS A WHOLE WITHOUT THE WRITTEN PERMISSION OF PLI IS PROHIBITED.	
APPROVED AS NOTED	COMMENTS:		Generic
REVISE AND RESUBMIT	SCALE	DWG. NO.	REV.
SIGNATURE	A		
	SCALE 1:16		SHEET 2 OF 4

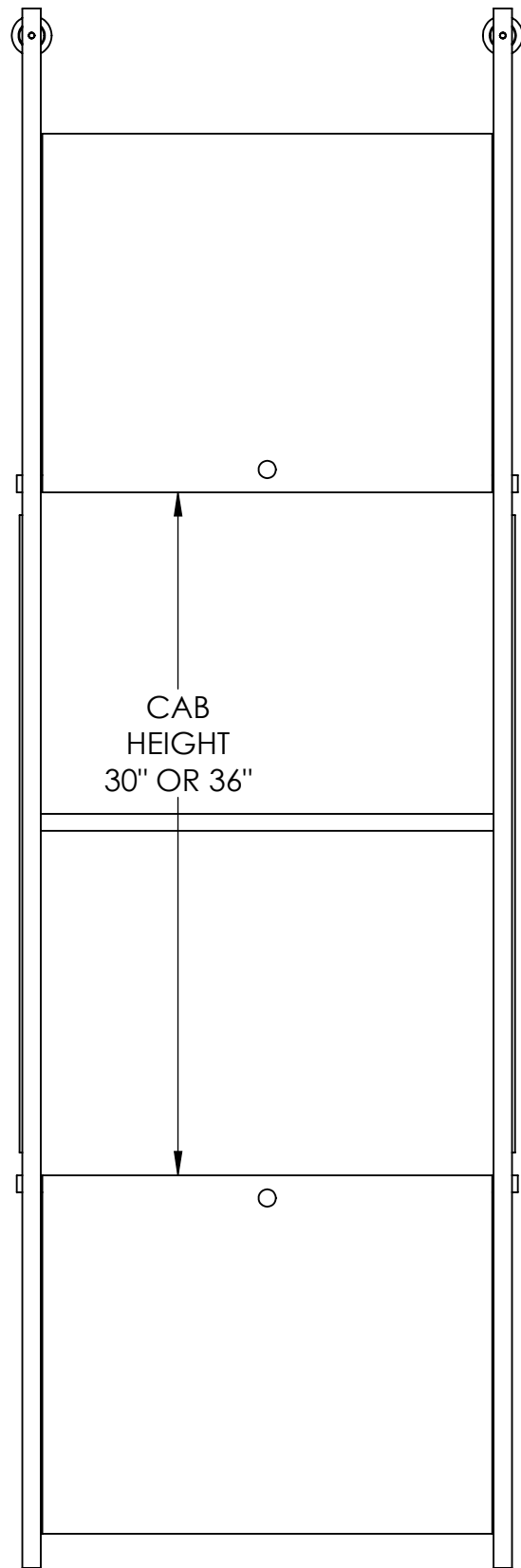

SEE CHART FOR SIZE AVAILABILITY

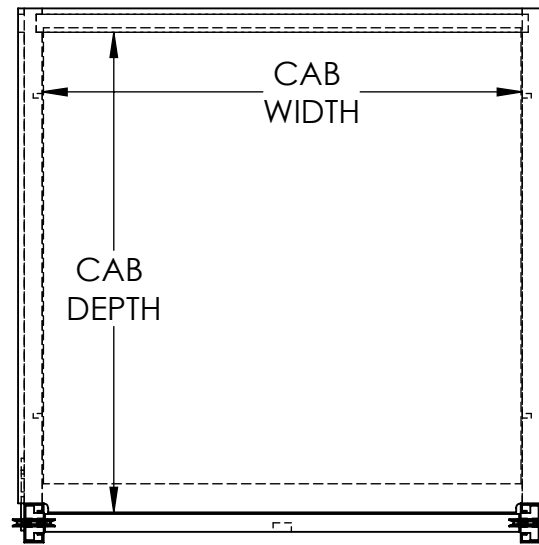

CAB MATERIAL OPTIONS	FINISH
WHITE LAMINATE	FLAT
BIRCH/MAPLE VENEER	UNFINISHED OR PREFINISHED
CHERRY VENEER	UNFINISHED OR PREFINISHED
MAHOGANY VENEER	UNFINISHED OR PREFINISHED
OAK VENEER	UNFINISHED OR PREFINISHED
FOOD GRADE HDPE	WHITE
STAINLESS STEEL	#4 BRUSHED

NOTE: STAINLESS AVAILABLE IN STANDARD SIZES ONLY

5 ADJUSTABLE SHELF HEIGHTS STANDARD

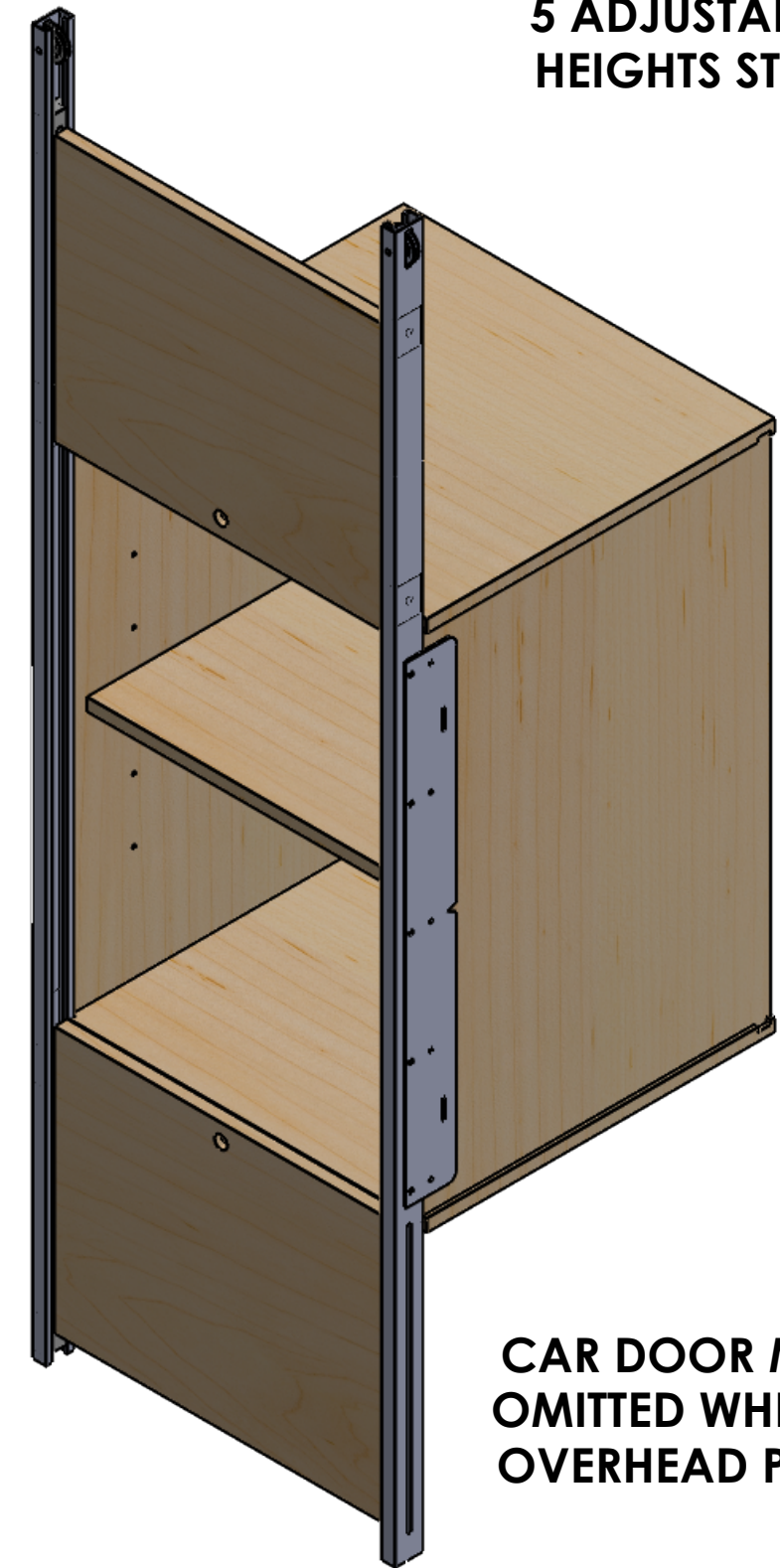

CAR DOOR MAY BE OMITTED WHEN LOW OVERHEAD PRESENT



DO NOT SCALE DRAWING	NAME	DATE	PROJECT NAME
	DRAWN		
APPROVAL STATUS:	PROPRIETARY AND CONFIDENTIAL		PROJECT LOCATION
APPROVED	THE INFORMATION CONTAINED IN THIS DRAWING IS THE SOLE PROPERTY OF AMERIGLIDE. ANY REPRODUCTION IN PART OR AS A WHOLE WITHOUT THE WRITTEN PERMISSION OF PLI IS PROHIBITED.		COMMENTS: Generic
APPROVED AS NOTED			
REVISE AND RESUBMIT			
SIGNATURE	SIZE A	DWG. NO.	REV.
	SCALE 1:16		SHEET 3 OF 4

ACCESS HATCH IF TOP MOUNT MOTOR

OVERHEAD
96" MINIMUM TYP

TOP
LANDING

LOADING
HEIGHT B
0" MIN
36" MAX

TOTAL TRAVEL =
DISTANCE FROM
BOTTOM LOADING
SILL TO TOP
LOADING SILL

Total
Hoistway
Height

UP TO 4 LANDINGS

FLOOR TO FLOOR
DISTANCE

BOTTOM
LANDING

LOADING
HEIGHT A
24" MIN

ACCESS HATCH

LOADING HEIGHTS ARE FIELD ADJUSTABLE



DO NOT SCALE DRAWING

APPROVAL STATUS:

- APPROVED
- APPROVED AS NOTED
- REVISE AND RESUBMIT

SIGNATURE

NAME	DATE
DRAWN KSB	2-11-19

PROJECT NAME

PROPRIETARY AND CONFIDENTIAL

PROJECT LOCATION

THE INFORMATION CONTAINED IN THIS DRAWING IS THE SOLE PROPERTY OF AMERIGLIDE. ANY REPRODUCTION IN PART OR AS A WHOLE WITHOUT THE WRITTEN PERMISSION OF PLI IS PROHIBITED.

COMMENTS:

Generic

SIZE DWG. NO.

A

REV.

SCALE 1:16

SHEET 4 OF 4